

## GENERAL

This Instruction Supplement covers important information for the use/adaptation of Model DT Direct Vent for pellet, corn and other pelletized bio-fuel fired appliance venting applications. In this application Model DT provides necessary outside combustion air directly to the appliance.

## Listing

In addition to being Listed as a direct vent system for gas fired direct vent appliances, Model DT Direct Vent has been tested and listed by Underwriters Laboratories, Inc. in accordance with UL641, the Standard for Low Temperature Gas Venting Systems and ULC/ORD-C441 for Pellet Vents. Model DT Vent is approved for venting listed pellet and corn stoves that do not exceed flue gas temperatures of 570° F (300°C).

**NOTE:** Refer to the main Model DT Direct Temp installation Instructions for further details on the use of this product. (Flashings, Supports, Offsets, Adjustables ..... Etc.) Read the appliance installation instructions for any further installation or layout restrictions.

Selkirk MetalBest Model DT has a 4" inner liner and a 6-5/8" outer jacket. It is permissible to adapt the Model DT to both a 3" and a 4" pellet stove outlet collar. Model DT can be adapted to Pellet Stoves with specially designed Adapters used in conjunction with one or more components (Tee, Short Length) of Selkirk Model VP L-Vent for Pellet Stoves.

## Minimum Clearance and Framing

Model DT has a 1" minimum airspace clearance to combustibles requirement when used as L Vent. This applies whether DT is being used to bring outside air to the pellet appliance or not. Do not fill this space with insulation or any other material. The airspace is required for the safe operation of the vent.

"Combustibles" include framing lumber, drywall, plaster, plywood, paneling and other building materials.

For penetrating walls, ceiling joists or roof joists the required framing dimensions are 8-5/8" x 8-5/8". This will provide a 1" clearance for a properly centered vent.

**NOTE:** While these instructions focus on proper installation of DT when outside air is being drawn to appliance, if other sources of combustion air are provided, DT may be used with the combustion air passageway blocked, still at 1" airspace clearance.

## ADAPTERS

### Pellet Stove Adapter

The Pellet Stove Adapter comes with an inlet end that will properly connect to Selkirk Model VP L-Vent and a standard Model DT outlet. It can be recognized by the presence of a 3" diameter air intake for bringing combustion air to the stove.

**⚠ WARNING**

Failure to follow the installation instructions could cause **FIRE, CARBON MONOXIDE POISONING, OR DEATH.** If you are unsure of installation requirements, call the Phone Number listed on the instructions, 1.800.433.6341 or visit [www.selkirkcorp.com](http://www.selkirkcorp.com).

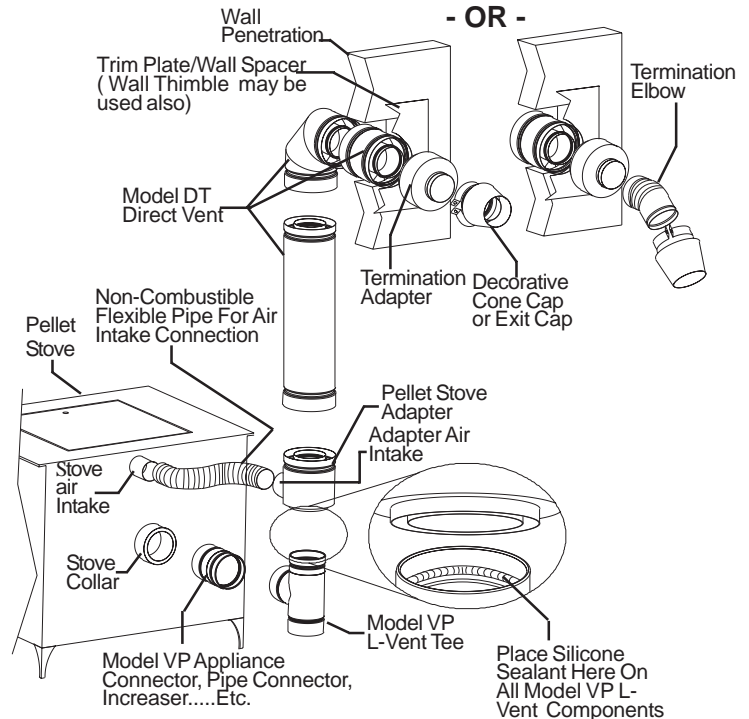

Through the Wall Installation

Fig. 1

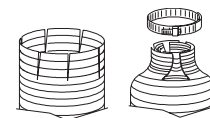
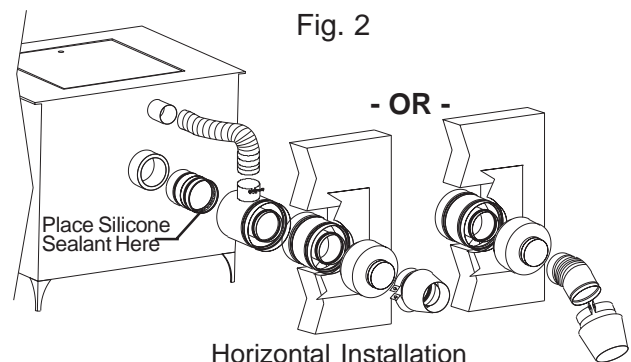

Fig. 2



Horizontal Installation

Fig. 3

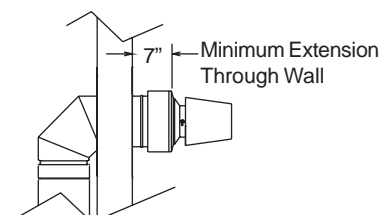

Fig. 4

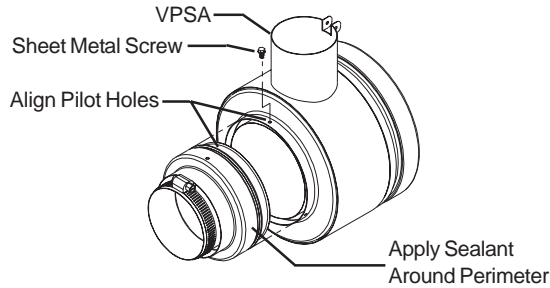

Fig. 5

Connect the pellet pipe to the Model DT Pellet Stove Adapter by pushing the inlet end of the adapter down over the outlet of the pellet pipe until fully seated. Screw the adapter to the pellet pipe using the three 1/4" #8 sheet metal screws provided. When connecting the Multi-Function Connector (MFC) to the DT Pellet Stove Adapter, a bead of sealant should also be applied to the outside perimeter of the MFC. To install the sheet metal screws, first align the pilot hole in the Stove Adapter with the hole in the MFC and install screw (See Fig. 5). Complete by installing the remaining 2 screws and connecting other sections of Model DT Direct Vent as needed following Model DT main instructions.

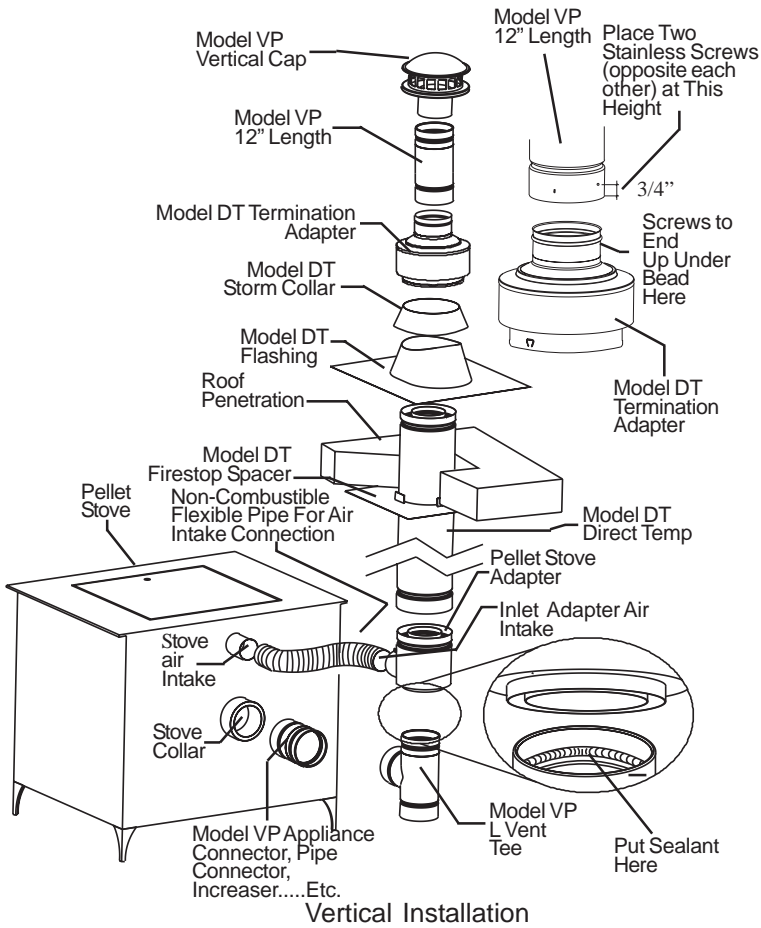

Fig. 6

### Connecting to Stove Air Intake

Connection of the stove air intake to the Pellet Stove Adapter (4DT-VP SA) can be made with the use of Selkirk's Combustion Air Kit (4DT-CAK) which comes with a 3 foot long section of aluminum flexible pipe (3" in diameter) and a hose clamp. Connect the flex pipe by inserting it into the combustion air snout of the Stove Adapter. Tighten by using the adapters integrated clamp tabs. Cut the aluminum flex pipe to the length necessary to reach the pellet stove combustion air inlet. Fit the aluminum flex pipe over the pellet stove combustion air inlet. If the diameter (OD) of the inlet is less than 3", make 4 to 6 three inch long parallel cuts equidistant around the circumference of the flex pipe end. Overlap the cut edges to reduce the flex pipe end diameter to the diameter of the stove combustion air inlet. Secure the flex pipe to the inlet using the hose clamp. (See Fig 2)

Note: The connection can be made as described with most non-combustible 3" flexible pipe and a hose clamp.

### Outlet Termination Adapter

The Termination Adapter comes with a standard Model DT Inlet connection and an outlet that will accommodate Selkirk's Decorative Cone Cap (4DT-DCC), Exit Cap (4VP-EC), Termination Elbow (DT-VPTE) and Vertical Cap (VP-VC). It can be recognized by the presence of an extra housing around the outlet end of the adapter which provides an intake air passage way.

**NOTE: The intake air passage way must remain free from obstruction at all times.**

Connect the adapter to the Model DT by sliding it over the Direct Vent that is either extending through the wall or through the roof depending on the type of installation. For through-the-wall installations using the Termination Elbow (4DT-VPTE), install and attach using one 1/4" stainless steel screw.

After obtaining the necessary parts of Model VP L-Vent that will be needed to convert the system to L-Vent, attach them to the pellet stove outlet.

Place a bead of high temperature silicone sealant around the perimeter of interior liner (at the end of the outlet) of the section of Model VP that will be connected to the Pellet Stove Adapter. **(Note: All Model VP components should be sealed in this manner.)**

See Fig. 1

Attach the Decorative Cone Cap (4DT-DCC) or Vertical Cap (VP-HC) to complete the system. See Sections on Vertical Termination, Horizontal Termination and Termination Elbow for more detail. Reference Figs 1-6 for guidance.

## ENCLOSURES

The vent system should be enclosed in occupied areas, closets, storage rooms, and accessible attics. This does not apply to the portion of the system that is in the same room as the Pellet Stove. Enclosures may be built of ordinary drywall or plywood at the required minimum of 1 INCH AIRSPACE CLEARANCE. There are no special parts to maintain clearance to inside surfaces of walls or enclosures. Therefore, the vent installer should take all necessary precautions to assure that this 1 inch minimum airspace is maintained. In unoccupied attics, it is very important to be sure that blown-in or other insulation does not come in contact with the vent system. A full enclosure in the attic should extend to the roof. However, it need only be finished well enough to keep insulation and stored furnishings away from the vent system.

**NOTE - Enclosures maintaining the minimum airspace clearance are especially important in attics insulated with CELLULOSE type insulation which may be composed of old newspapers and other cellulose materials which are very susceptible to ignition of a fire.**

Also the enclosure, by protecting the vent from cold outdoor temperatures, may improve appliance operation.

A vent system enclosure is also recommended for any exterior systems and portions extending through unheated areas. This enclosure is helpful in reducing internal condensation, residue buildup from products of combustion and metal deterioration.

## MODEL VP 12" LENGTH AT TERMINATION

It is required to install a 12" length of Model VP at the Termination Adapter. Push pipe length down onto the adapter until fully seated. Attach by drilling two holes (opposite each other and approximately 3/4" up from inlet end of pipe) through outer wall and secure with two 1/4" long #8 stainless steel sheet metal screws. See Fig. 6.

## VERTICAL TERMINATION CAP (VP-VC)

The Vertical Termination Cap is intended for use in all installations in which the vent terminates in a vertical orientation. The cap provides necessary protection of the vent system from rain and other elements.

To Install: Push the cap down onto the section of Model VP until the spring clips engage. No additional attachment is required. (See Fig. 6)

**TERMINATION HEIGHT ABOVE ROOF**—The termination of Model VP should be located a sufficient distance from the roof so that the discharge opening is at least two (2) feet above the roof surface, or nearby structure.

## HORIZONTAL DECORATIVE CONE CAP (4DT-DCC)

The Decorative Cone Cap is designed specifically for use on installations in which the vent terminates in a horizontal orientation on the outside of a structure.

To Install: Slide the Cone Cap onto the Outlet Adapter or Termination Elbow (if using) until fully seated. Using the screw and nut provided, tighten the Cone Cap clamp band around the adapter outlet until a snug fit is achieved.

## EXIT CAP (VP-EC)

The Exit Cone Cap is designed to direct flue gases perpendicular to the wall and to increase their velocity, projecting them further away from the building.

**Note:** When using the Exit Cone Cap, make sure it will be installed so that the hot flue gases do not overheat any of the surrounding area or pose any burn hazard to humans.

To Install: Slide the Exit Cone Cap onto the Termination Adapter until fully seated. While holding cap in place, drill two holes into the adapter using the holes near the inlet end of Exit Cap as a guide. Secure with screws provided.

## TERMINATION ELBOW (4DT-VPTE)

The Termination Elbow is used in through-the-wall installations and provides for redirection of exhaust gases if needed or desired. (See Fig. 1 and Fig.3)

To install: insert the inlet end of the elbow into the outlet end of the Termination Adapter until fully seated. Attach with one stainless steel, #8, 1/4" screw.

## RULES FOR DISTANCES FROM HORIZONTAL EXIT TERMINATIONS

General VENT layout is shown in Figures 1 through 4.

The termination of a sidewall vent serving a pellet/corn-burning appliance shall be located to avoid personal burn injury, fire hazard and interference with or damage to adjacent properties.

A clear space of at least 1m (3ft) shall be provided from the termination to any building projection, adjacent wall, or any combustible materials such as trees, shrubs, fencing, etc.

Guards shall be provided around the termination of the sidewall venting system to prevent:

- (a) Individuals from accidentally running into the venting system;
- (b) Mechanical damage from occurring as a result of vehicle traffic.

In selecting the location for the appliance and the vent, it is necessary to take into account the rules of NFPA 211, ULC/ORD-C441 and any applicable local codes.

#### **When installed in the USA:**

At the time of printing of this document, many codes did not include clear and specific guidelines for the termination locations for pellet fired appliance incorporating direct vent systems.

Selkirk recommends installing the referenced terminations in accordance with the guidelines for "Direct Vent" termination locations per NFPA211. These guidelines are:

- The vent terminal of a direct vent appliance with an input of 10,000 Btu/hr (2930 W) or less shall be located at least 6 in. (152 mm) from any opening into a building
- The vent terminal of a direct vent appliance with an input of over 10,000 Btu/hr (2930 W) but not over 50,000 Btu/hr (14,650 W) shall be located not less than 9 in. (229 mm) from any opening through which vent gases could enter a building,

The vent terminal of a direct vent appliance with an input over 50,000 Btu/hr (14,650 W) shall be located not less than 12 in. (305 mm) from the opening.

- In all cases, the bottom of the vent terminal and the air intake shall be located at least 12 in. (305 mm) above grade."

Alternatively, some code authorities may consider these terminations as "Mechanical Draft Systems" and insist they be located per NFPA211 requirements for same. In such case, the following guidelines for minimum distances from the exit termination to doors, windows, air inlets, etc. are applicable.

Terminations for mechanical draft systems shall be located:

- Not less than 3 ft. (0.91 m) above any forced air inlet located within 10 ft. (3m).
- Not less than 4 ft. (1.2m) below, 4 ft. (1.2m) horizontally from, or 1 ft. (305m) above any door, window or gravity inlet into any building, and
- Not less than 2 ft. (0.6m) from an adjacent building and not less than 7 ft. (2.1m) above grade when located adjacent to public walkways.
- So that flue gases are not directed so they jeopardize people, overheat combustible structures, or enter buildings.

#### **When installed in Canada:**

For a Horizontal Termination ULC/ORD-C441 has the following restrictions: Vent length must not exceed 1200mm (48"). The Termination must not be located:

- (a) Within 1.8 m (6 ft) of a mechanical air supply inlet to a building.
- (b) Above a gas meter/regulator within 900 mm (36") horizontally of vertical centreline of the regulator.
- (c) Within 1.8 m (6 ft) of a gas service regulator vent outlet or within 1m (3ft) of an oil tank vent or an oil tank fill inlet.
- (d) Less than 300 mm (12") above grade level or any surface that may support snow, ice, or debris.
- (e) Within 1 m (3 ft) of a building opening or air inlet of another appliance.
- (f) Within 1m (3ft) of the property boundary.
- (g) Underneath a veranda, porch or deck.
- (h) Less than 2.1m (7ft) above any public sidewalk, lane, street, or right-of-way.

#### **MAINTENANCE REQUIREMENTS**

Refer to the appliance manufacturer's maintenance instructions for recommendations relative to required maintenance of your appliance.

—Model DT, when used as an L-Vent system, requires periodic inspection and cleaning with an appropriately sized brush which will not scratch the inside surface of the flue. **DO NOT USE** chemical cleaners to clean your venting system

—Frequency of necessary vent system cleaning will vary with the appliance, vent system configuration and climate. Certain pellet burning appliances or pelletized fuels may give off more fine dust than others.

—In any case it is recommended that the complete assembly be inspected and cleaned (if any buildup has occurred) at the beginning of each heating season and at least monthly thereafter.

—**TO INSPECT AND CLEAN . . .** Remove the termination cap by removing any screws, then rotating and pulling until it disengages. Remove the tee cap(s) by removing the stop screw and pulling the cap off. Inspect system. If necessary clean by running a brush through the system several times in each direction. **NOTE** - Be sure that tee and termination caps are reinstalled and secured when Inspection/Cleaning is completed and before the system is put back in use.

0015208-1009