

Front View

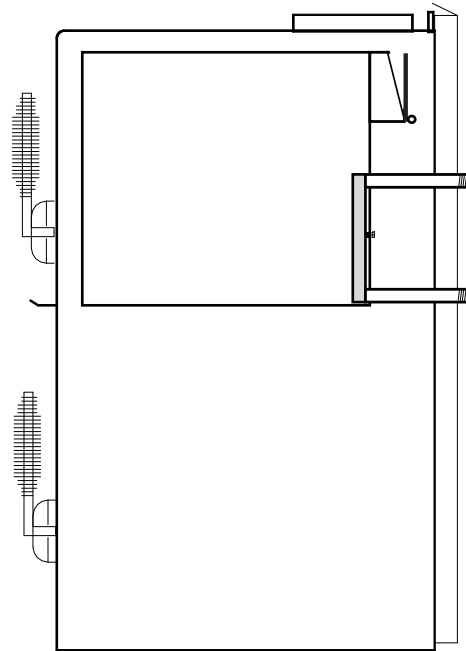

Side View

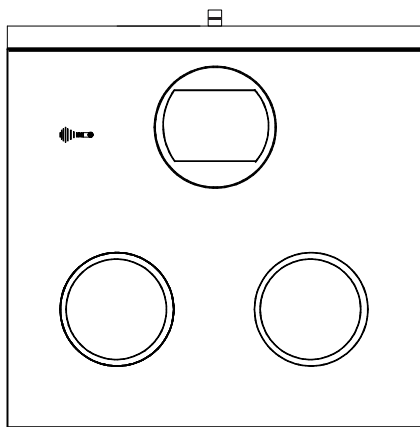

Top View

Nectre Water Booster Factory Fitted Bakers Oven

Located at the base of the firebox and fixed to the rear with a centre 8mm bolt, the Nectre water booster is manufactured to the highest standard to ensure maximum efficiency is achieved for heating of a domestic low pressure water system. The Bakers Oven range with Nectre water booster provides excellent sustainable energy living and contributes to reducing the overall carbon footprint.

- » Pipe : 3/4" BSP stainless steel Inlet and Outlet pipe.
- » Material : manufactured using certified boiler grade stainless steel.
- » Dimensions : 14.5" x 8.2" x 1"
- » Volume : approx 0.26 gallon
- » Installation : it is recommend that a licensed plumber complete the installation of the Nectre Bakers Oven with a factory fitted water booster.



Pecan Engineering Pty Limited
13 Acorn Road, Dry Creek
South Australia, 5094
T +61 8 8349 8332
E info@pecan-eng.com.au

nectre.com