

No Utility Bills Inc.

www.noutilitybills.com

#301 Tower Road South, P.O. Box 2190, Stn Main, Athabasca, AB, T9S 2B7

Tel: (780)628-4835

VIEWINGS BY APPOINTMENT ONLY!

Benjamin Indoor Wood Boilers

Features Include:

- The firebox is completely surrounded with water to absorb the greatest heat possible from the wood combustion.
- The "Dutch Oven" concept of completely surrounding the firebox with cooling water, prevents damage from overheating and eliminates the need for firebrick.
 - Designed for use as an add-on to the primary heating boiler.
 - No messy fire tubes to clean.
 - Compact size uses less of your valuable floor space.
 - Boiler unit made of steel plate for long life.
 - With proper installation, the unit may be operated as gravity unit in case of power failure.
 - CAN/CSA B366.1 & UL 391-1995



Specifications DO-110

- Shipping Weight: 525 lbs
- 28"l x 24"w x 32"h
- Breech Pipe 8" I.D.
- Large 20"diameter x 24" firebox
- 12" x 14" Fire Door
- Will take 24" long log
- Capacity: 31 US Gallons
- 1-1/4" supply and return
- Domestic Hot Water Coil Standard

Specifications DO-180

- Shipping Weight: 730 lbs
- 41"l x 27"w x 36"h
- Breech Pipe 8" I.D.
- Large 24"diameter x 36" firebox
- 12" x 14" Fire Door
- Will take 36" long log
- Capacity: 54 US Gallons
- 1-1/4" supply and return
- Domestic Hot Water Coil Standard

No Utility Bills Inc.

www.noutilitybills.com

#301 Tower Road South, P.O. Box 2190, Stn Main, Athabasca, AB, T9S 2B7

Tel: (780)628-4835

VIEWINGS BY APPOINTMENT ONLY!

Typical Add On Installation - Preferred Design

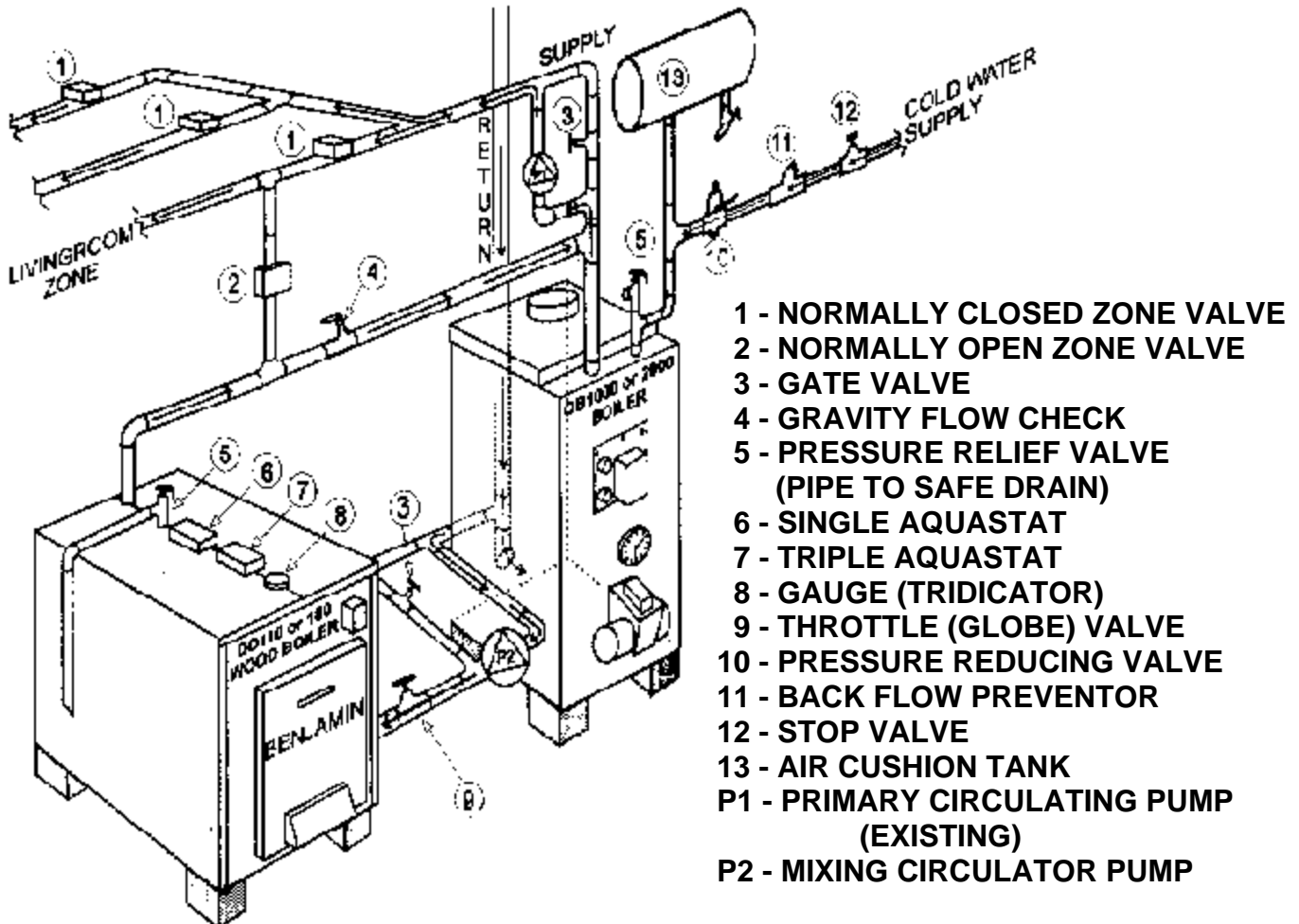

Typical Add On Installation Kit Included With Boiler

- Pressure Safety Relief Valve
 - 1/2" Drain Valve
 - Damper Motor & Chain
- Two 110-24 Volt Transformers
 - Triple Aquastat
- Combination Pressure & Temperature Gauge
 - Normally Open Zone Valve